

SIRUBA[®] Sew Reach

操作手冊

OPERATION MANUAL

700K DKKU1



CE

重要安全聲明

SAFETY INSTRUCTIONS

使用前請詳閱本說明書，如果在使用上有任何疑問，歡迎隨時與本公司聯繫。

Please review the manual carefully before using of the controller. Please feel free to contact with us if you have any question and comment. For controller installment and maintenance,

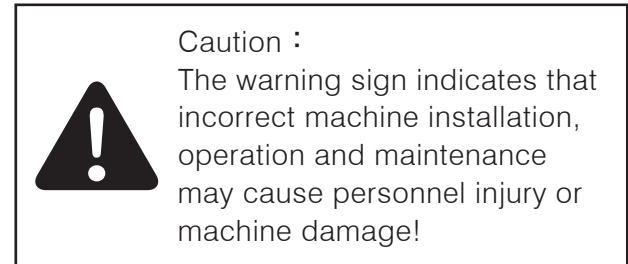
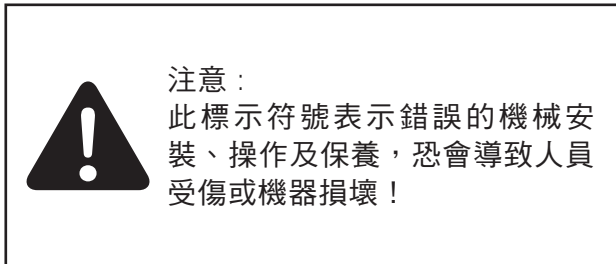

安裝及維修作業請由專業人員處理。

Please contact with qualified technician for assistance.

1. 電機接通電源時請不要把腳放在腳踏板上
2. 本產品需專業人員安裝，調試
3. 嚴禁在通電時打開控制箱與電機端蓋
4. 必須保證系統接地可靠
5. 以下操作請務必斷電
 - A. 換針、穿線或更換底線時
 - B. 安裝、拆卸或修理時
 - C. 翻抬縫紉機時

1. Do not place your foot onto the pedal when connecting to the power source.
2. Installation and trial-run must be done by skilled person.
3. Open control box or motor cover under electrical power is not permitted.
4. Make sure the earthing system is working well.
5. When doing the following the machine has to be disconnected from the power supply.
 - A. When threading machine, replacing needle, bottom thread.
 - B. When install, dismantle and repair.
 - C. When turn over the sewing machine.

作業環境要求：

1. 請不要在過潮濕的環境中作業
2. 用戶供電應保持穩定 AC 210V~240V
3. 用戶使用前必須接地，確保人身安全
4. 不要在過熱地方作業
5. 控制系統與電機不要在強磁高輻射環境中作業，以免干擾而使系統錯誤

Environmental Requirements:

1. Please do not work at damp place.
2. The voltage requires being stable (AC 210V~240V).
3. Must be adequately grounded for safety
4. Do not work at high temperature
5. Do not run motor and control system near to ferromagnetic or high-radiance area

務必使用本公司提供或認可的零部件維修。

All the replacement parts for repairing must be provide or approved by supplier.

索引	INDEX	頁 /PAGE
產品介紹	PRODUCT INSTRUCTIONS	1
控制台使用說明	CONTROL PANEL INSTRUCTION	3
安裝調試	INSTALLATION AND TRIAL-RUN	6
故障排除	ERROR CODE & TROUBLE SHOOTING	9
保修服務	WARRANTY SERVICE	10

產品介紹

本產品由本公司自主研發，產品個性鮮明，真正體現出了機電一體化的概念，更是節能、高效、環保、優美集結於一身。可廣泛適用於多種縫紉設備。

1. 組成部分：
控制器系統由控制器和電機兩部分：

PRODUCT INTRODUCTION

This product by the company independent research and development, distinct personality, truly reflects the concept of mechanical and electrical integration, more energy saving, high efficiency, environmental protection, beautiful assembled in one. It can be widely applied to a variety of sewing equipment.

1. Component:
The servomotor is composed of control system and motor:



A. 控制器：控制箱和速控器。

A. Control system includes control box and speed controller.

系統介面連接和操作面板示意圖如下：

Introduce for control panel:

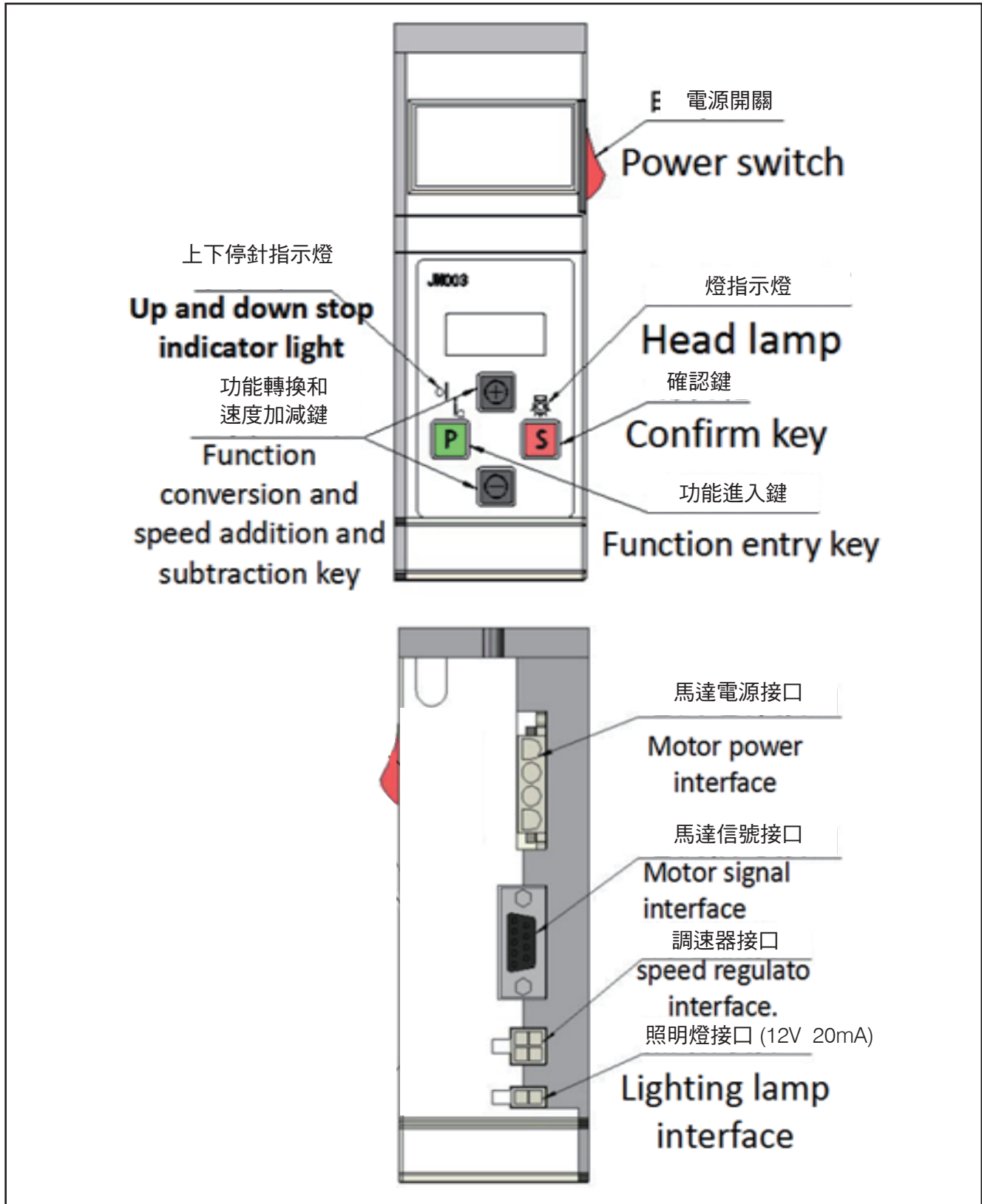

控制台使用說明

INSTALLATION FOR CONTROL PANEL

1. 各按鍵的用途：

(1) “P” 鍵的用途：

第一：“P” 鍵為上、下停針鍵，按下“P” 鍵，上燈孔亮，為上停針；下燈孔亮，為下停針；兩個燈孔都不亮，為自由停針；

第二：功能進入鍵（見進入參數的操作方法）

(2) “S” 鍵的用途：

第一：“S” 鍵為燈開關鍵，按下“S” 鍵，當“S” 鍵上的小燈亮為打開燈，滅為關掉燈。

第二：功能參數（確認）鍵（見進入參數的操作方法）

(3) “+” “-” 鍵的用途：

此兩個鍵用於轉速調整和參數調整。

2. 進入參數的操作方法

例：怎樣把電機的順時針轉調到逆時針轉：

第一步：打開電源；

第二步：先按“P” 鍵不放，同時按“+” 號鍵，此時畫面會顯示 P-00。

第三步：按“+” 號鍵，把 P-00 調至 P-02，（P-02）就是電機正反轉參數（常用參數表上有標明）；

第四步：按下“P” 鍵畫面會顯示“1”；

第五步：按下“-” 號鍵把“1” 調到“0”（“1” 為順時針轉，“0” 為逆時針轉，常用參數表上有標明）；

第六步：按下“S” 鍵確定參數調整完成。

1. Each key purpose:

(1) Function of “P” key:

First: “P” key for upper and lower stop needle position. Press “P”, if up pinhole lamp lights means it's up stop needle, if down pinhole lamp lights means that it is down stop needle, if two lamps off means needle position is freedom.

Second: Function Enter button (below) to enter the parameter method of operation

(2) Function of “S” key:

First: “S” button for off or on the head lamp. Press “S” key the lamp lights, if don't do it is turn off.

Second: Function Enter button (below) to enter the parameter method of operation

(3) Function of “+” 、 “-” key

These two keys are used to adjust speed and parameter modulation.

2. To enter the parameter method of operation:

Example: How to change the motor from clockwise to counterclockwise:

Step one : Open the power;

Step two : Press the ” P” key, no leave, and press “+” key, the screen will display the P-00;

Step third: Press “+” key, change the P-00 to P-02, (P-02) is a motor clockwise or counterclockwise parameters (common parameter list has record);

Step four: Now press “P” key (enter into parameters) screen will display “1” ;

Step fifth: Press “-” key, change “1” to “0” ; (“1” for clockwise, “0” for the counter clockwise rotation, commonly used in the parameter table is indicated);

Step six : Press the “S” key to determine the parameters, save and exit the parameter.

3. 恢復出廠設置

恢復出廠設置方法：先按“P”鍵不放，同時按“+”號鍵，此時畫面會顯示 P-00，再長按“S”鍵約 3 秒即可。

3. Restore factory settings

Restore factory settings: Press the “P” key, no leave, and press the “+” key, the screen will display the P-00, then press “S” key 3 seconds.

4. 電機常用參數設置

4. Commonly used parameter setting

序號 The serial number	參數編號 Parameters name	參數名稱 The parameters name	參數範圍 Adjusting rang		出廠設置 The factory reset settings	備註
1	P-01	最大速度鎖定 Maximum Speed lock	200-6500RPM		4500 轉	
2	P-02	電機方向 Direction of rotation	0 是逆時針 0 is reverse turn needle	1 是順時針 1 is clockwise turn	1	老款平縫電機調到 2 或 3 Old flat seam motor change to 2 or 3
3	P-03	下停角度 The needle angle	6-18°		12°	
4	P-04	起縫速度 Start sewing speed	200-800 轉		250 轉	
5	P-05	加速快慢 Speed up And slow	2000-4000 轉		3500 轉	
6	P-06	定針縫 Set the seam	0-999 針		0	
7	P-07					
8	P-08					
9	P-09					
10	P-10	自動間隙運行(跑合) Automatic Clearance run (run)	把 0 改成 1 再按 S 鍵 Press the S key when change 0 to 1		0	
11	P-11	抬壓腳起動時間 Presser foot ascend starting time	0-2000ms			
12	P-12	抬壓腳保護時間 Ascension presser foot protection time	1-120s			
13	P-13	老款平車電機選擇 Old section flat sewing machine selection	1 是老款平縫機電機 Motor option 1 is old section flat sewing machine		0	0 是普通機 0 is ordinary sewing machine
14	P-14	最大電流限制 Maximum current limiting	50-1000		280	
15	P-15	是否檢測上針位 Whether to detect the up needle position	1: 檢測針位, 0: 不檢測 1: detecting needle 0: no detection		1	

本控制系統體現出了超前的設計理念，系統操作簡單易上手，整個控制系統性能優越。具有起步快，停車快、准等優點。而且電路模組保護功能完善：有欠壓、過流、等一系列保護功能。速控器可實現無級調速。

This control system features is easy to use and features in excellent performance, including quick start, quick stop (sewing machine), accurate needle position. Furthermore, the modular circuit has Self-Protection System when against lower voltage, over current, over heat etc. speedcontroller is realized by the pedal speeder.

B. 電機：

電機轉子屬於稀土永磁材料，具備功率大，節能環保等各大優點。電機內設有霍爾感測器，使電機具有準確的上下定位，使電機體積更小更美觀。

B:Motor

Rotor is made of rare earth permanent magnet, guarantee high power and environmental. Exactly needle UP/DOWN position due to its built-in Hall type sensor and compact design.

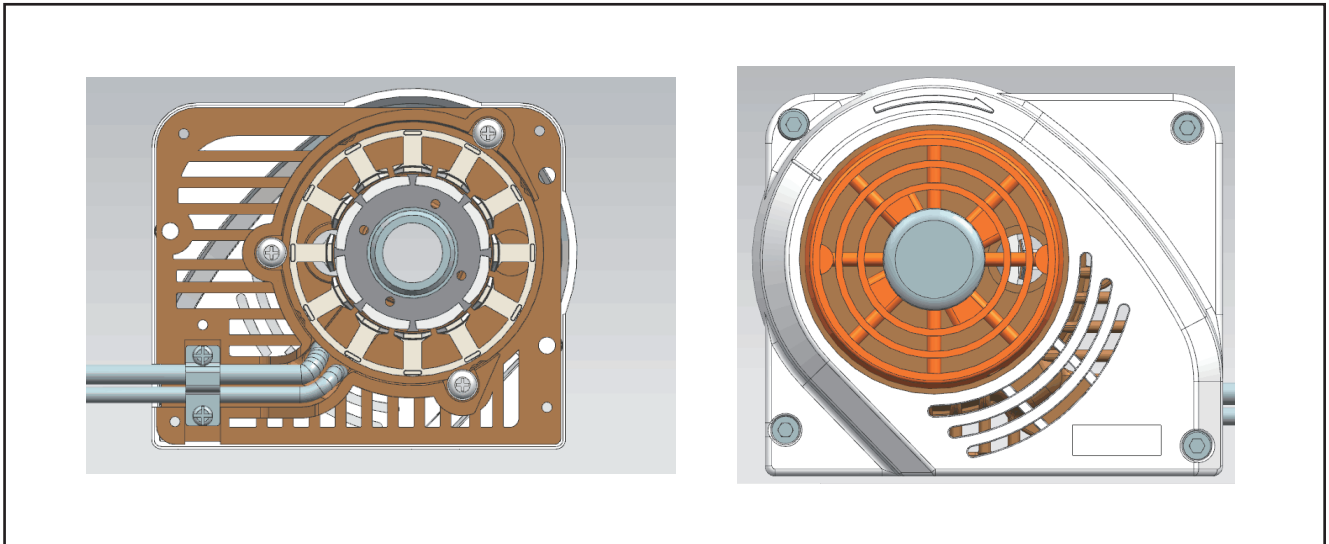

C. 產品組裝效果圖：

C.Product assembly demonstration:



2. 性能參數指標

2. Specifications

電源供電電壓 Voltage	220V 單相 220V 1 phase
頻 率 Frequency	50~60 HZ
電機轉速 Speed	200-6500 RPM
電機扭矩 Motor torque	400W ≤ 2 N.M

安裝調試：直驅式電機安裝方法

INSTALLATION AND TRIAL-RUN
(DIRECT DRIVE TYPE)

1. 控制箱速控器安裝如下圖
將控制箱和速控器用螺釘依次安裝在縫紉機台板上。

1. Install control box and speedcontroller as below figure
Using screws, mount the Control Box and speedcontroller onto sewing table properly.

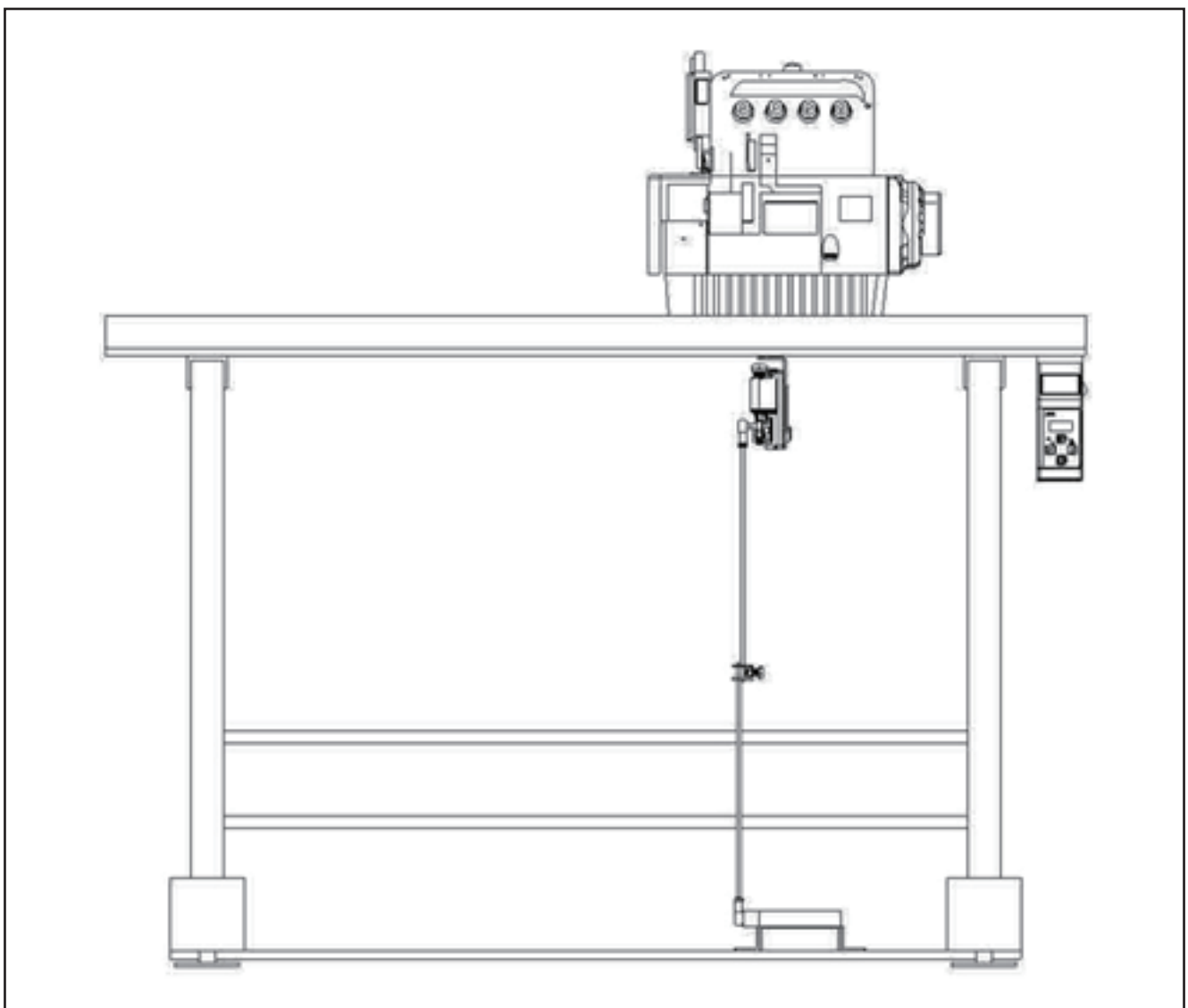

2. 直驅電機安裝示意圖：

2.Schematic diagram of the installation of direct drive motor

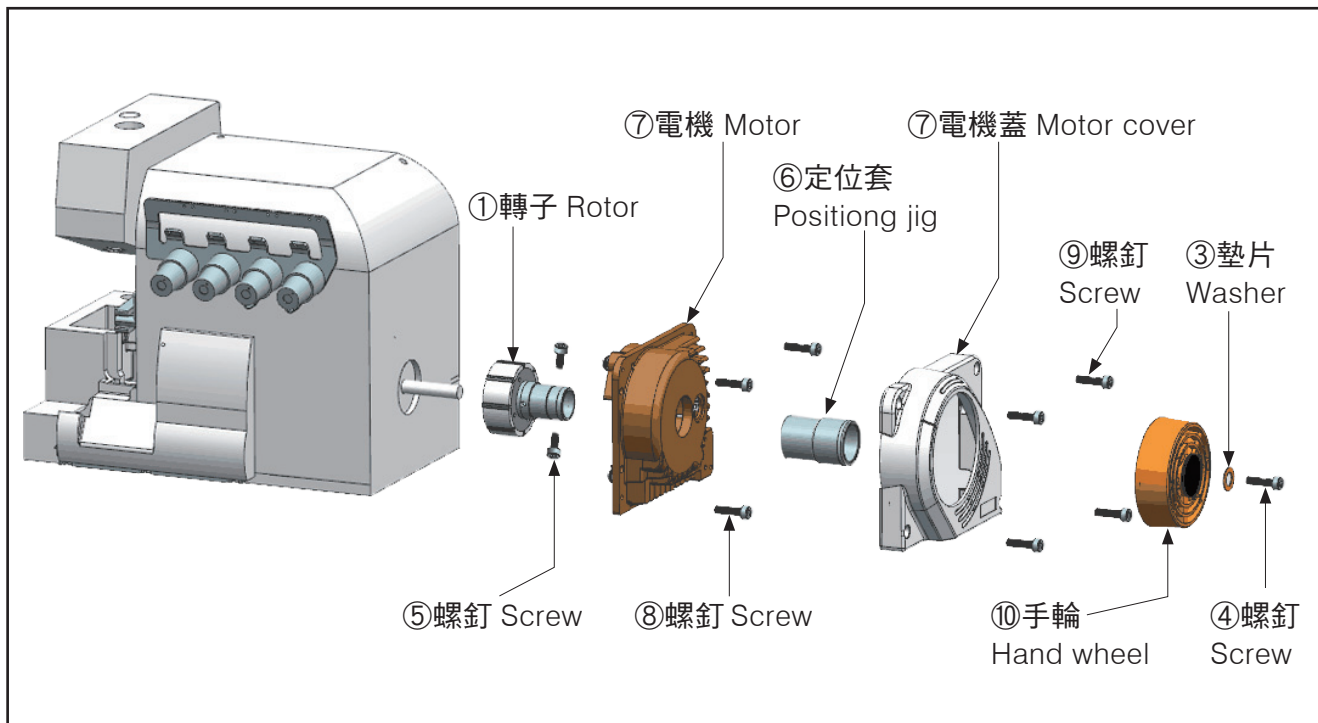

直驅電機安裝共 5 步驟：

5. Motor installation of a total of 5 steps:

(1) 裝轉子：

- A) 拆掉縫紉機上的手輪、皮帶罩和風葉。
 - B) 將圖①轉子裝入縫紉機軸上，用圖③墊片和圖④螺釘固定住轉子，再鎖緊圖⑤兩個螺釘。
- 檢查 1：用右手抓緊轉子，左手轉動大心要無自轉現象。
- 檢查 2：用手轉動縫紉機應無加重。

(1) Install rotor

- A) Remove the hand wheel, belt cover and wind blade on the sewing machine.
 - B) Figure ② rotor install into the shaft of sewing machine in the picture, fixed rotor with figure ③ gasket and figure ④ screw, then fix figure ⑤ two screws.
- Check 1: Clutch rotor with right hand, the left hand turns the fan to have no rotation.
- Check 2: Hand rotation of the sewing machine should not increase heavy.

(2) 裝電機：用專用塑膠定位套圖⑥卡在電機圖⑦孔 $\phi 30$ 內，對準圖①轉子裝入縫紉機，用圖⑧螺釘固定，螺釘擰緊後要能輕鬆拔出定位套。（注：定子裝入轉子要注意磁鐵吸力，小心夾到手。）

(2) Install motor: Using a special plastic locating figure ⑥ card in the motor map positioning hole whose diameter ⑦ is 30, install into sewing machine directed at figure ① rotor, then fixed with figure ⑧ screws, screw down to be able to easily pull out the positioning sleeve.(Notes: The stator into the rotor should pay attention to the magnet suction, carefully clip hand.)

(3) 裝手輪：

- A) 用手轉動縫紉機，使機針停在最高位
- B) 將手輪裝入轉子並將刻度 1 字對準電機外殼的刻度線（看圖 B）。轉緊安裝示意圖上的圖⑤ 2 個螺釘。

(3) Install hand wheel

- A) Turn the sewing by hand , make the needle stop at the highest level
- B) Put the hand wheel in the rotor, and mark the calibration line of the motor housing with the scale 1 (As Pic.B).

- (4) 檢查：手轉動手輪無摩擦現象，縫紉機也無加重。

- (4) Check: Hand wheel hand wheel without card wiping phenomenon, Sewing machine weight does not increase.



圖 B (Pic.B)

故障排除

ERROR CODE & TROUBLE SHOOTING

序號 The serial number	錯誤碼 Error code	錯誤內容 Error content	錯誤問題的多種可能 Several possible error problem
1	Er01	找不到停針位 Can't find the needle position	<ol style="list-style-type: none"> 1. 手輪靠的不夠近間隙在 2.5mm 內 2. 九針插頭接觸不良 3. 電機霍爾壞，要更換電機 4. 手輪上的磁鐵掉落 <ol style="list-style-type: none"> 1. The hand wheel is not close, clearance within 2.5 mm 2. Nine plug contact undesirable 3. Motor holzer bad, to replace the motor 4. The hand wheel magnet in the loss
2	Er02	開機沒有檢測到調速器 Not detected boot speed regulator	<ol style="list-style-type: none"> 1. 調速器插頭沒有插 2. 調速器線斷了或接觸不良 <ol style="list-style-type: none"> 1. Speed control device without plug 2. Speed wire is broken or contact undesirable
3	Er03	電機霍爾或相位線錯誤 Motor holzer or phase error	<ol style="list-style-type: none"> 1. 九針插頭接觸不良 2. 電機沒有安裝好，參照圖 A 3. 霍爾壞 <ol style="list-style-type: none"> 1. Nine hole plug contact undesirable 2. The motor doesn't pack good 3. Holzer is bad
4	Er04	堵轉保護 Locked-rotor protection	<ol style="list-style-type: none"> 1. 電機超載 2. 電機與電控相連接的四心線接觸不好 3. 電機斷線或壞了 <ol style="list-style-type: none"> 1. The motor overload 2. The motor and the controller connected four hole line contact is not good 3. Motor is bad
5	Er05	硬體過流保護 Hardware over-current protection	<ol style="list-style-type: none"> 1. 電機超載 2. 信號線接觸不好或斷了 3. 主機板壞了 <ol style="list-style-type: none"> 1. The motor overload 2. Line contact is bad or broken 3. Main board is bad
6	Er07	串口通信逾時錯誤 Serial port communication timeout error	顯示幕至主機板信號線不良或主機板壞 Display to the system board signal is bad or board is bad
7		顯示幕無電開關有電 Screen without electricity Switch with electricity	<ol style="list-style-type: none"> 1. 主機板壞 2. 顯示幕與主機板連接線接觸不良 <ol style="list-style-type: none"> 1. Main board is broken 2. The display screen and the main board connection line contact is bad

保修服務

WARRANTY SERVICE

1. 本產品自購買起免費保修 2 年，終身維護。保修期內除人為損壞以外出現任何品質問題可免費維修
2. 在保修期內，以下情況出現損壞本公司不給於保修服務：
 - A. 未經本公司同意自行拆卸、修理、改裝造成的故障或損壞。
3. 但凡出現無法解決的問題可以聯繫本公司。

1. Since from the purchase of this product, the free 2-year warranty, lifetime maintenance. During the warranty period, any quality problems the product will be free repaired, except artificial damage.
2. In the warranty period, the following circumstances appear to damage the company does not give the warranty service.
 - A. Dismantle the motor unit without permission and cause damage.
3. Whenever find the problem can not be solved, you can contact with our company.



高林股份有限公司
KAULIN MFG. CO., LTD.

由於對產品的改良及更新，本產品使用說明書中與零件圖之產品及外觀的修改恕不事先通知！
 The specification and/or appearances of the equipment described in this instruction book & parts list are subject to change because of modification which will without previous notice.
 700K DKKU.MAR.2018